

°C

%RH

SHIMADEN

Series **SD17 & KR17**

## SHIMADEN DIGITAL INDICATOR



### BASIC FEATURES

- *DIN size 48 × 96 mm*
- *±0.3% high accuracy indication*
- *Large 20 mm bright display:  
Easy to read from long distances or dark and dim places*
- *Universal-input, multi-range*
- *Normal and inverse scaling for voltage and current inputs and analog outputs*
- *IP66 dust and splash-proof front panel*
- *Wide range of optional features:  
Alarms, analog outputs, 24V DC sensor power supply, and communication interface RS-485 or RS-232C (Shimaden standard protocol/MODBUS)*
- *Can be combined with six-point rotary selector switch KR17 Series*
- *Improved visibility with selectable red or white LED*

■ Power saving by turning off indication



To save power consumption during operation, the ECO mode turns off the display with a screen-saver feature; power consumption is cut by 48%. Even with the display off, you can notice the device is running as the ECO lamp flashes.

The display automatically resumes if an alarm has occurred. The type of abnormality can be identified by the optional alarm feature instead of the default display blinking.

■ More readable display

The adoption of an 11-segment display improves readability

▼ SD17



▼ SD16A (previous model)



■ Improved visibility

The optional white LED enables a monitoring of process regardless of the ambient brightness and distances. This two-color LED system also enables a function where if an alarm occurs, the display uses the other color to indicate an abnormality.

▼ Red and white LEDs



▼ Alarm output



! New feature  
To indicate an alarm occurrence, either or both of the following actions can be set:  
- Blinking the display of the measured value  
- Changing the display color of the measured value to the other color, from red to white or from white to red (optional red and white LEDs required)

■ Scaling possible for linear input (mV, V, mA), inverse scaling possible

The industrial value for the input signal is displayed (up to 10,000 counts).

■ IP66 dust and splash-proof front display and operating part

Prevents dust and moisture invasion through the front side after mounting to the panel

■ High accuracy of  $\pm 0.3\%$

A high accuracy of display enables precision measurement

■ CE Marking certified

Conformity to European Union (EU) safety performance standards

■ Combination with a rotary selector switch





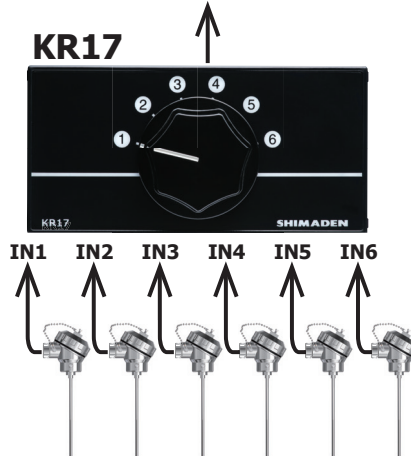

Six-point display can be used if combined with a rotary selector switch (KR17).

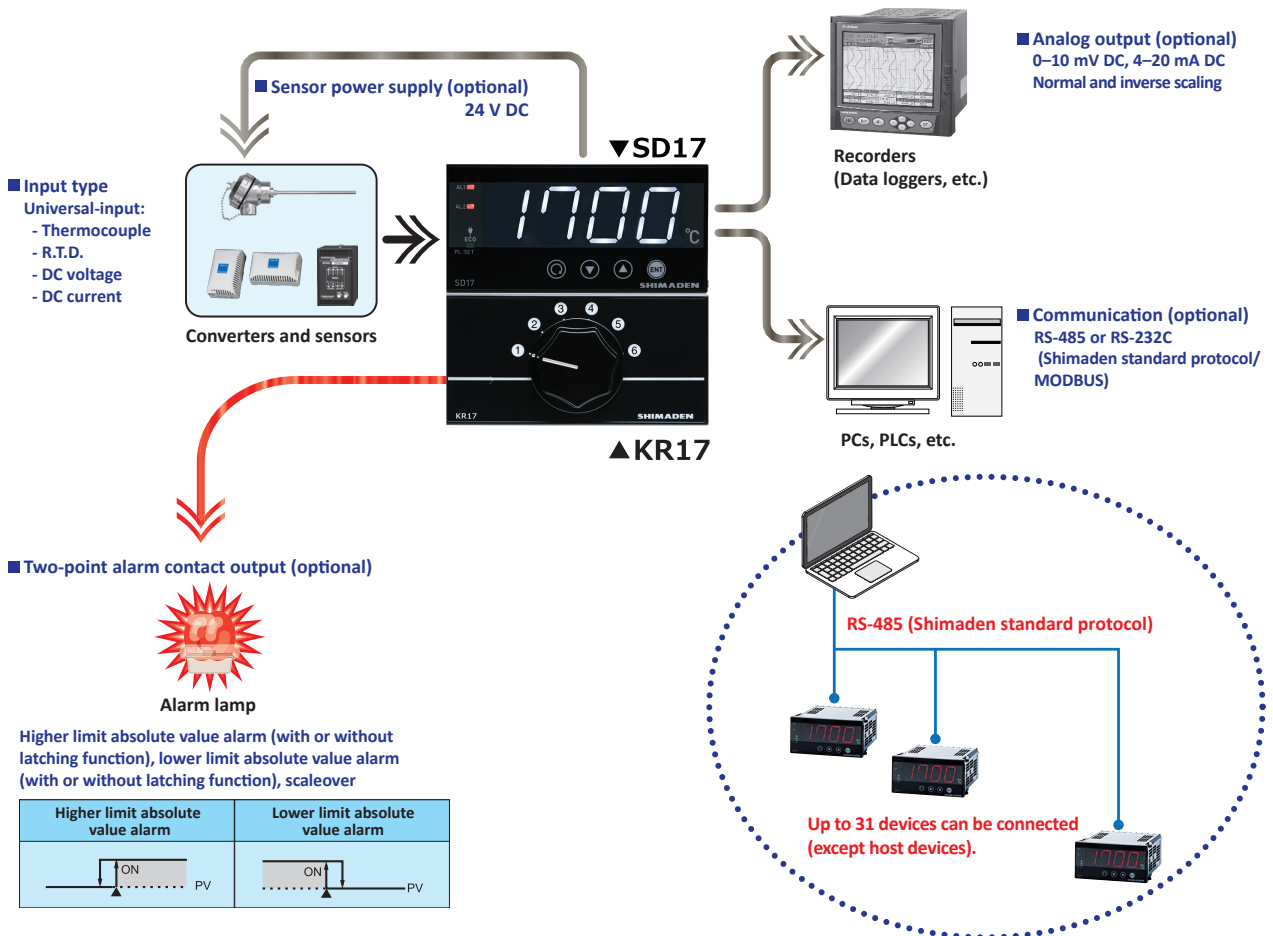

▲ When mounted in a stack with a KR17 rotary selector switch, the size of the front is 96 × 96 mm.

■ Example of use and features



<b>■ Display</b>	
● Display system	
Digital display	: Process value (PV): 11-segment, 4-digit red LED (approx. 20 mm character height); (Optional) 11-segment, 4-digit white LED (approx. 20 mm character height)
Status display	: PL/SET (ECO): Green LED AL1: Red LED AL2: Red LED
● Display accuracy	: $\pm(0.3\%FS + 1 \text{ digit})$ (in measuring range, excluding cold junction error for thermocouple input) Notes: 1. When T or U thermocouple indicates $-100^{\circ}C$ to $0^{\circ}C$ , $\pm(0.5\%FS + 1 \text{ digit})$ ; when $-100^{\circ}C$ or less, $\pm(1\%FS + 1 \text{ digit})$ 2. When B thermocouple indicates $400^{\circ}C$ or less: Accuracy $\pm(5\%FS)$
● Display accuracy range	: $23\pm 5^{\circ}C$
● Display resolution	: Depends on measuring range (0.01–1)
● Measured value display range	: $-10\%$ – $110\%$ measuring range (accuracy not guaranteed outside measuring range)
● Display update cycle	: Adjustable from 0.25 to 5.00 sec. (0.25 sec. step) Note: If 0.5 sec. or more is set, there may be a difference between the displayed value and the analog output (AO) and communication data.
● Input scaling	: Scaling possible for linear input (mV, V, mA), inverse scaling possible Setting range: $-1999$ – $9999$ digit; Span: $10$ – $10000$ digit Decimal point position: 1, 0.1, 0.01, 0.001
● Screen saver	: If there is no operation on the device for a set period of time, from 0 to 100 min., the 11-segment LED is turned off and the ECO lamp flashes. Note: The display resumes if an alarm occurs.
● Color switching (optional)	: Set the default display color (red or white), and the color changes to the other in the case of an alarm.
<b>■ Setting</b>	
● Setting system	: By four front key switches (  ,  ,  ,  )
● Setting protection	: Keylock ON/OFF
<b>■ Input</b>	
● Input type	: Universal-input, multi-range
● Thermocouple	: Input resistance: $500k\Omega$ or more Lead wire tolerable resistance: $100\Omega$ or less Burnout: Standard up-scale Cold junction compensation accuracy: $\pm 1^{\circ}C$ in the ambient temperature range of $18^{\circ}C$ to $28^{\circ}C$ (accuracy maintaining range); $\pm 2^{\circ}C$ in the ambient temperature ranges of $5^{\circ}C$ to $18^{\circ}C$ and $28^{\circ}C$ to $45^{\circ}C$
● R.T.D.	: Amperage: approx. $0.25 \text{ mA}$ Lead wire tolerable resistance: $5\Omega$ or less (if the three wires have the same resistance)
● Voltage (V) input	: Input resistance: $500k\Omega$ or more
● Current (mA) input	: Through external receiving impedance ( $250\Omega$ , attached if specified)
● Isolation	: Isolated between input and analog output (sensor power supply), or between input and communication. Not isolated between input and system.
<b>■ Alarm output (optional)</b>	
● Contact output rating	: Normal open (1a): $240 \text{ V AC}$ , $1.5 \text{ A}$ (resistive load)
● No. of outputs	: Two points
● Alarm type	: None, higher limit absolute value alarm, lower limit absolute value alarm, higher limit absolute value alarm with latching, lower limit absolute value alarm with latching, scaleover
● Setting range	: Within measuring range or scaling range
● Alarm action	: ON/OFF
● Alarm sensitivity	: $1$ – $999$ digit within measuring range (cannot exceed the scaling span)
● Output updating cycle	: $0.25 \text{ sec.}$
● Standby action	: ON/OFF settable for each of Alarm 1 and 2
● Isolation	: Isolated between alarms (except between Alarm 1 and 2 (AL1–AL2)); isolated from input, analog output (sensor power supply), communication, and system.

■ Analog output (optional)	
● Analog output type	: 0–10 mV (10Ω output resistance) 0–10 V (1 mA or less load current) 4–20 mA (300Ω or less load resistance)
● Resolution	: Approx. 1/14000
● Output accuracy	: ±0.3%FS for displayed value
● Scaling	: Normal and inverse scaling within measuring range or input scaling range
● Output update cycle	: 0.25 sec.
● Isolation	: Isolated from alarm, input, communication, and system.
■ Communication (optional)	
● Communication type	: RS-232C, RS-485
● Communication system	: Half duplex start-stop synchronized system
● Communication speed	: 1200, 2400, 4800, 9600, 19200
● Data format	: 7E1, 7E2, 7N1, 7N2, 8E1, 8E2, 8N1, 8N2
● Communication address	: 1–100
● No. of connected devices	: RS-485: up to 31; RS-232C: 1
● Communication delay	: 0–100 msec.
● Communication protocol	: Shimaden standard protocol, MODBUS ASCII, MODBUS RTU
● Communication code	: Shimaden standard protocol: ASCII MODBUS ASCII: ASCII MODBUS RTU: binary
● Others	: Starting character and BBC operation method can be selected.
● Isolation	: Isolated from alarm, input, analog output (sensor power supply), and system.
■ Sensor power supply (optional)	
● Rating	: 24±3 V DC, 25 mA or less
● ON/OFF	: Depends on the device's ON/OFF
● Isolation	: Isolated from alarm, input, communication, and system.
● Restrictions	: Not selectable if analog output is selected or if the device's supply voltage is 24 V.
■ General specifications	
● Data storage	: Non-volatile memory (EEPROM)
● Operating environment	: Temperature: -10–50°C Humidity: 90%RH or less (no dew condensation) Elevation: 2000 m or less Overvoltage category: II Pollution class: 2 (IEC 60664)
● Storage temperature	: -20–65°C
● Supply voltage	: 100–240 V±10%, AC 50/60 Hz; (Optional) 24 V±10%, AC 50/60 Hz or DC
● Power consumption	: Max. 11 VA (100–240 V AC) 8 VA (24 V AC) 5 W (24 V DC)
● Applicable standard	: Safety standard: IEC 61010-1 and EN 61010-1; IEC 61010-2-30 and EN 61010-2-30 EMC standard: EN 61326-1 Complies with RoHS Directive
● Dust and splash-proof structure	: IP66 equivalent (applied only to the front side if mounted to a 1.2–3.2 mm thick panel)
● Insulation resistance	: Between input/output terminal and power terminal: 500 V DC, 20MΩ or more Between input/output terminal and earthing terminal: 500 V DC, 20MΩ or more
● Dielectric strength	: Between input/output and power supply: 3000 V AC for 1 min. Between power supply and ground: 1500 V AC for 1 min.
● Case color and material	: Black/PPE (UL94V-1 equivalent)
● External dimensions	: H48 × W96 × D111 mm (100 mm depth inside the mounting panel)
● Installation	: One-touch mounting through panel cutout (panel thickness 1.0–4.0 mm required)
● Weight	: Approx. 250 g

ITEM	CODE		SPECIFICATIONS	
SERIES	SD17-		Digital indicator (DIN size 48 × 96 mm)	
INPUT*1	8		Universal-input: - Thermocouple - R.T.D.: Pt100/JPt100 - Voltage: 0–10 mV DC; 0–5, 1–5, and 0–10 V DC (input resistance 500kΩ or more)	For details on input type and measuring range, see Measuring Range Codes. Normal and inverse scaling can be used for voltage input.*2
		4		Current: 4–20 mA DC (250Ω external receiving impedance attached)
POWER SUPPLY	*3	90-	100–240 V±10%, AC 50/60 Hz	
		08-	24 V±10%, AC 50/60 Hz or DC	
ALARM		0	Without	
		1	Two-point individual setting and output (a-type contact) Contact capacity: 240 V AC, 1.5 A (resistive load)	
ANALOG OUTPUT OR SENSOR POWER SUPPLY	*3	0	Without	
		3	Analog output: 0–10 mV DC, 10Ω output resistance	Normal and inverse scaling (within measuring range)
		4	Analog output: 4–20 mA DC, 300Ω or less load resistance	
		6	Analog output: 0–10 V DC, 1 mA or less load current	
8	Sensor power supply: 24 V DC, 25 mA or less			
COMMUNICATION		0	Without	
		5	RS-485: Shimaden standard protocol/MODBUS	
		7	RS-232C: Shimaden standard protocol/MODBUS	
DISPLAY		0	11-segment red LED	Alarm action: display blinking
		1	11-segment red and white LEDs	Alarm action: display color switching and/or display blinking
REMARKS		0	Without	
		9	With	

\*1 Although the SD17 is fully universal-input, we have two codes for input specifications as only the current input specification comes with an external receiving impedance (250Ω). If you do not need an external receiving impedance, select code 8.

\*2 Scaling range: -1999–9999 digit; Scaling span: 10–10000 digit

\*3 If you select code 08- (24 V AC/DC) for the "power supply," you cannot select code 8 (sensor power supply) for the "analog output or sensor power supply."

## MEASURING RANGE CODES

INPUT	TYPE	CODE	MEASURING RANGE (°C)	MEASURING RANGE (°F)	
Universal input*1	Thermocouple	B	01 *2	0–1800	0–3300
		R	02	0–1700	0–3100
		S	03	0–1700	0–3100
		K	04	-199.9–800.0	-300–1500
			05	0–1200	0–2200
		E	06	0–700	0–1300
		J	07	0–600	0–1100
		T	08 *3	-199.9–300.0	-300–600
		N	09	0–1300	0–2300
		U	10 *3	-199.9–300.0	-300–600
		L	11	0–600	0–1100
		C (WRe 5-26)	12	0–2300	0–4200
	R.T.D.	Pt	31 *4	-199.9–600.0	-300–1100
32			-100.0–100.0	-150.0–200.0	
JPt		33 *4	-199.9–500.0	-300–1000	
		34	-100.0–100.0	-150.0–200.0	
Voltage	0–10 mV	71	Initial value: 0.0–100.0 Normal and inverse scaling: Scaling range: -1999–9999 digit Scaling span : 10–10000 digit		
	0–5 V	81			
	1–5 V	82			
	0–10 V	83			
Current	4–20 mA	95			

\*1 The factory default setting is as follows:

Universal input	K	0–1200	°C
Current input	4–20 mA	0.0–100.0	No unit

\*2 Accuracy is not guaranteed at 400°C (752°F) or less.

\*3 Accuracy deteriorates to ±(0.5%FS + 1 digit) from -100°C to 0°C, and to ±(1%FS + 1 digit) at -100°C or less.

\*4 Scaleover occurs at -240.0°C (-400°F).

Note: For thermocouple and R.T.D. inputs with a measuring range having a decimal point, it is possible not to display the numbers below the decimal point.

■ Terminal arrangement

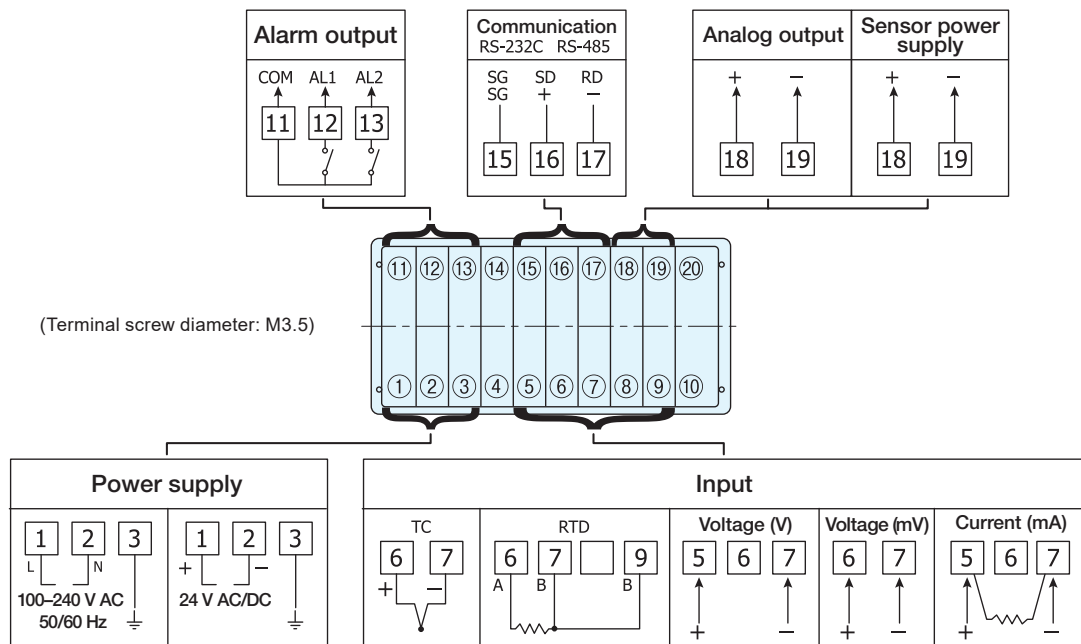

● Terminal cover (sold separately)

Model	Fixture
QCR004 (installed if the device is mounted alone)	Two screws of +B tight M2.3×6
QCR005 (installed if a plurality of SD17s and KR17s are mounted vertically)	Four screws of +B tight M2.3×6

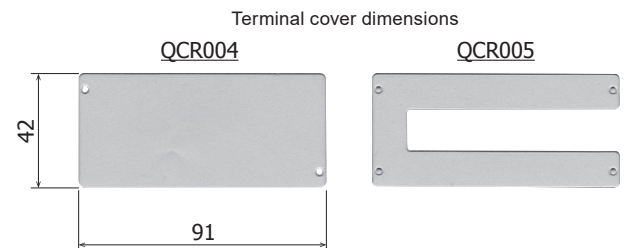

■ SD17 dimensions and panel cutout

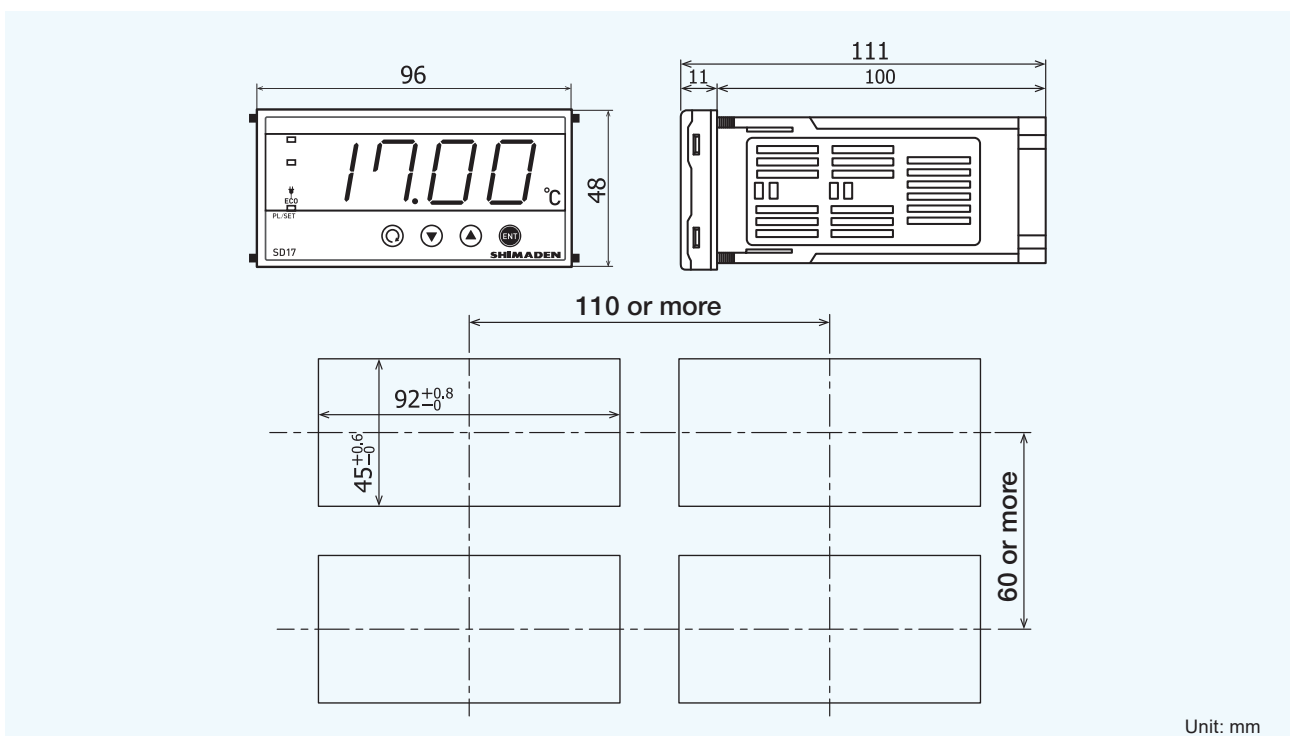

**SPECIFICATIONS**

- No. of switching points : 6
- No. of switching circuits : 2
- Switching operation : Rotary switching
- Applicable signal : Thermocouple, voltage (R.T.D. not supported)
  
- Contact rating : Contact method: Contact slide  
 Current: Max. 100 mA DC  
 Voltage: Max. 30 V DC  
 Contact resistance: Max. 300mΩ
  
- Operating ambient temperature range : -10~50°C
- Operating ambient humidity range : 90%RH or less (no dew condensation)
- Applicable standard : Safety standard:  
 IEC 61010-1 and EN 61010-1;  
 IEC 61010-2-030 and EN 61010-2-030  
 EMC standard: EN 61326-1  
 Complies with RoHS Directive
  
- Material : PPE resin
- Color : Case: Munsell N1 equivalent  
 Front side: Munsell N1 equivalent
  
- External dimensions : H48 × W96 × D128 mm  
 (100 mm depth inside the mounting panel)
  
- Panel cutout : H45 × W92 mm
- Installation : One-touch mounting through panel cutout
- Panel thickness : 1.0~4.0 mm
- Weight : Approx. 250 g

**ORDERING INFORMATION**

ITEM	CODE	SPECIFICATIONS
SERIES	KR17-	Six-point rotary selector switch
REMARKS	0	Without
	9	With

**TERMINALS, DIMENSIONS, AND PANEL CUTOUT**

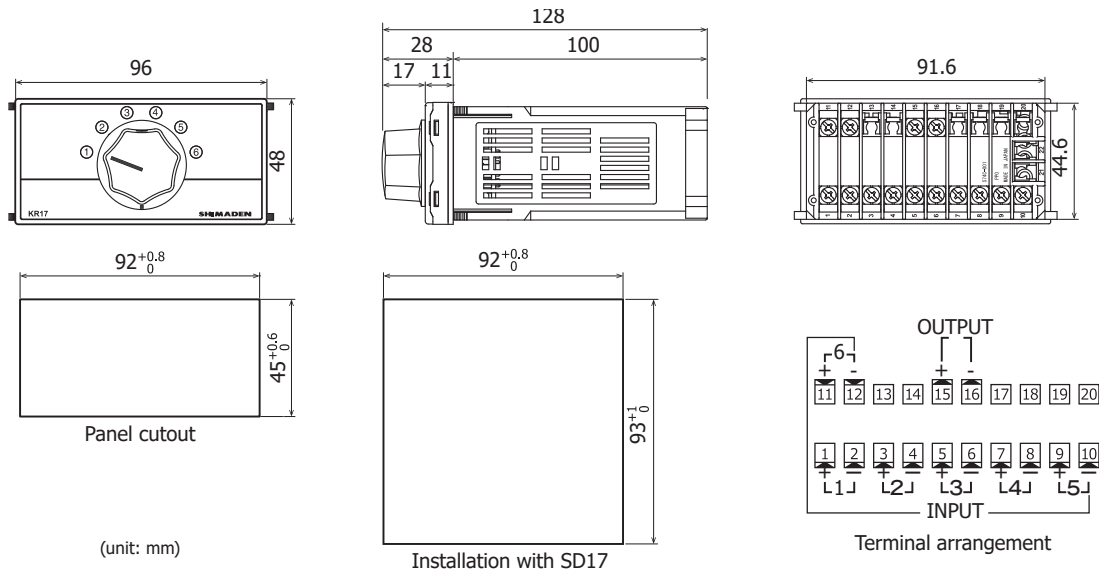

**Warning**

- The SD17 & KR17 series are designed for the control of temperature, humidity and other physical values of general industrial equipment. (They are not to be used for any purpose which regulates the prevention of serious effects on human life or safety.)

**Caution**

- If the possibility of loss or damage to your system or property as a result of failure of any part of the process exists, proper safety measures must be made before the instrument is put into use so as to prevent the occurrence of trouble.

**Head Office & Saitama Factory**  
**ISO 9001/ISO 14001 Certification Obtained**

(The contents of this brochure are subject to change without notice.)

**Temperature and Humidity Control Specialists**  
**SHIMADEN CO., LTD.**

Head Office: 2-30-10 Kitamachi, Nerima-Ku, Tokyo 179-0081 Japan  
 Phone: +81-3-3931-7891 Fax: +81-3-3931-3089  
 E-MAIL: exp-dept@shimaden.co.jp URL: http://www.shimaden.co.jp